

# Princeton FRC

## *A Compact Nuclear Fusion Power Plant*

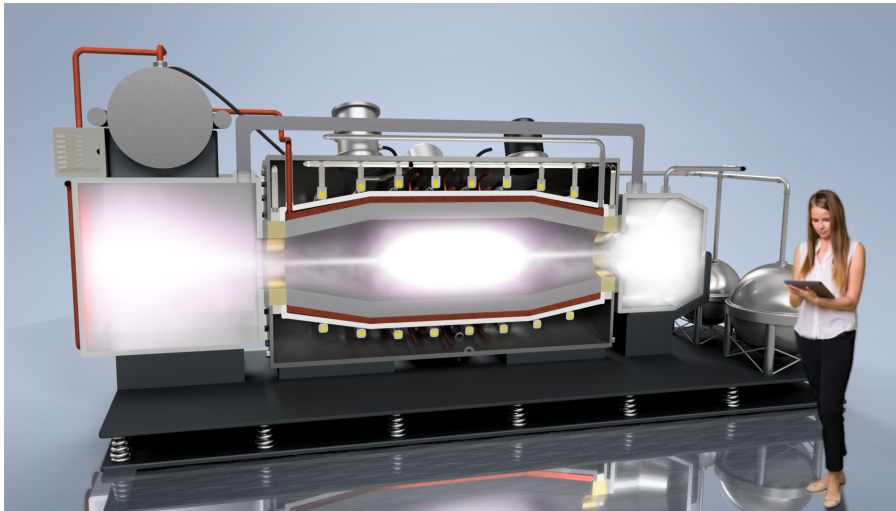

*PFRC Engineering Design*

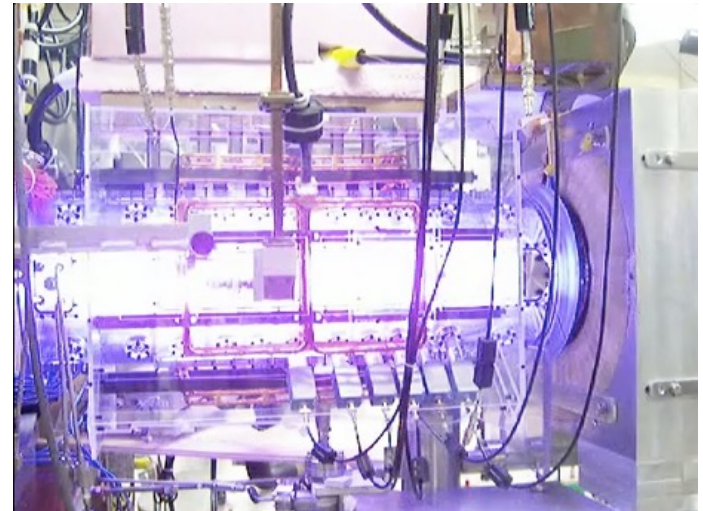

*PFRC-2 in operation at PPPL*

Michael Paluszek  
Princeton Fusion Systems

# Why Build a Small, Clean, Fusion Reactor?

*PFRC will produce 1-10 MWe per mini-van size reactor, with almost no radiation.*

## Civil

- Distributed and remote power
- Mobile and emergency power
- Load following supplement to wind, hydro and solar
- Modular power

## Space

- Deep space missions
- Lunar/Mars settlements
- Asteroid/comet intervention
- Space platform power
- High power Earth observation satellites
- High power communications satellites

## Military Terrestrial

- Submarines
- Upper atmosphere cruise vehicles
- Large UAVs
- Distributed power on surface ships
- Forward deployment
- Remote locations

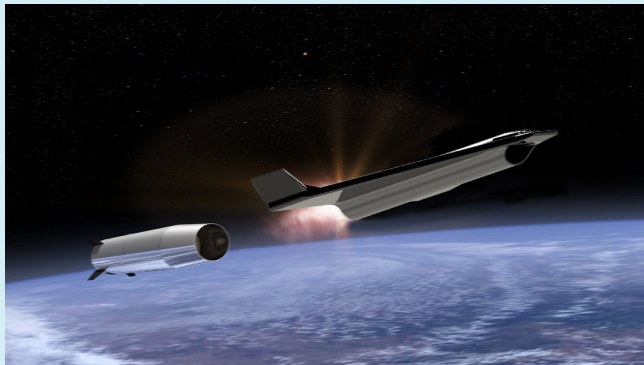

Extreme Altitude Hypersonic Cruise Vehicle  
*Image courtesy Captain Ryan Weed, USAF*

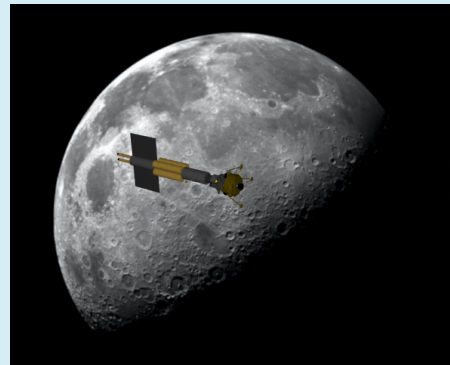

Lunar Transport



PFRC on an HEMTT for Forward Power

# PFRC Technology: Simple, Small, Clean

- **BREAKTHROUGH magnetic plasma heating method**

- Unique invention of PPPL's Dr. Sam Cohen
- Enables new small reactors

- **Simple**

- Linear array of magnetic coils
- Solenoid coils are a few T
- Mirror coils are 10-20 T would use hybrid LTS/HTS coils
- No tritium breeding

- **Small**

- FRC: Field-Reversed Configuration, a compact toroid

- **Clean**

- Very few damaging particles generated
- No radioactive or hazardous fuels required

- **Result: cheaper and faster to develop than other fusion concepts**

- Fusion power has only been generated in large Tokamaks (PPPL TFTR, JET)
- Large machines are expensive to develop and only useful for large centralized power plants, ex. ITER
- Development time frame is about the same as SMRs
- Safe for the battlefield

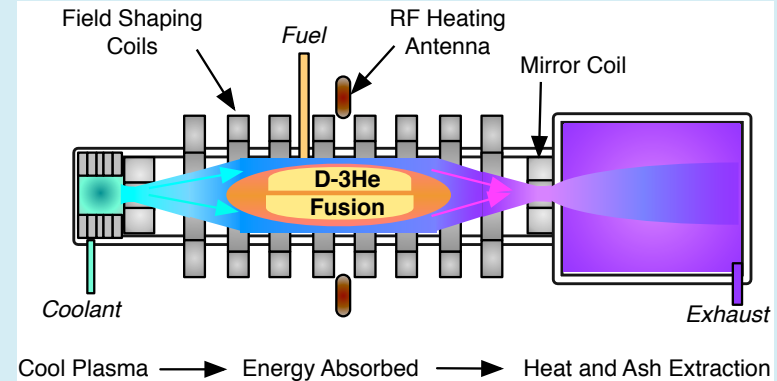

*PFRC Schematic*

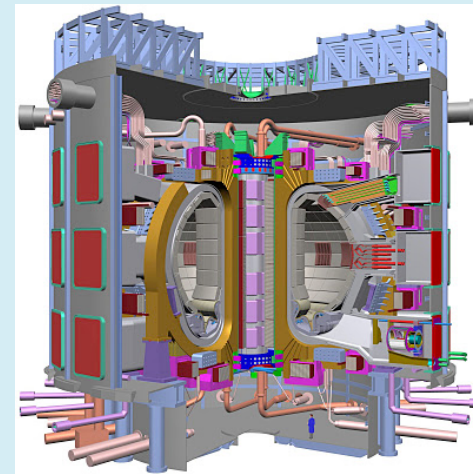

*PFRC is 1/1000 size of ITER*

# PFRC/DFD SUPPORT from NASA and DOE

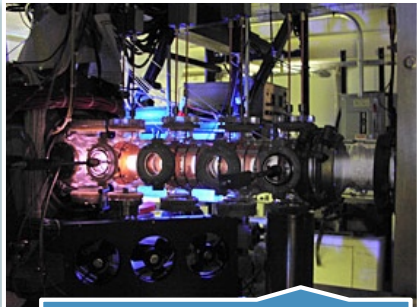

MNX  
DOE 1998-2015

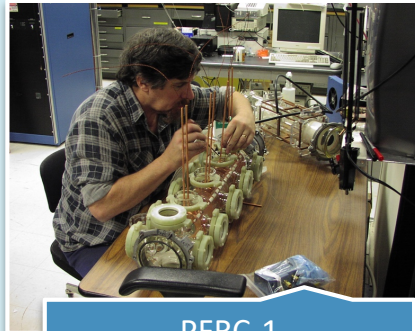

PFRC-1  
DOE FES 2002-2009



PFRC-2  
DOE FES 2010-2016

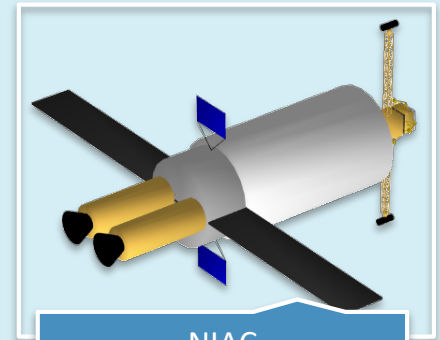

NIAC  
NASA 2016-2019

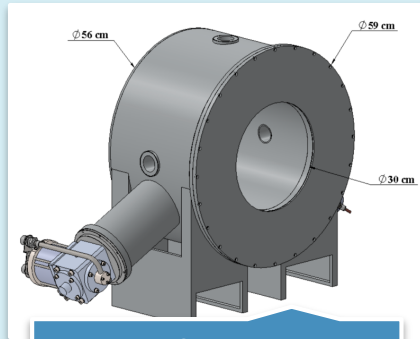

STTRs  
NASA 2017-2020



ARPA-E OPEN  
2019-2020

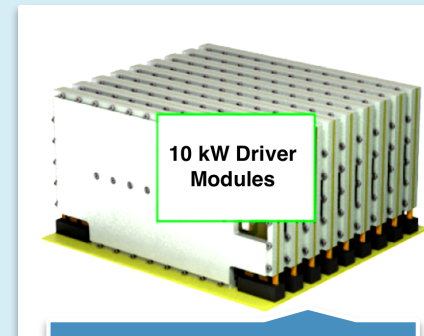

10 kW Driver  
Modules  
ARPA-E GAMOW  
2020-2023

# Ongoing Work

- **Ion heating experiment (ARPA-E OPEN)**
  - Ion heating experiments to demonstrate the heating method – expect results in September or October
- **Reactor design (ARPA-E OPEN)**
  - Performed an end-to-end engineering design for the reactor
  - Preparing for an operational machine
- **Superconducting coil (NASA STTR)**
  - Testing the impact of plasma transients on the superconducting coils
- Mars transfer vehicle with DFD and a nuclear thermal stage for orbit departure and entry (IR&D)
- Awarded ARPA-E GAMOW contract to develop high power drivers for fusion heating and control.
- Supporting a master's student thesis in FRC control UC San Diego

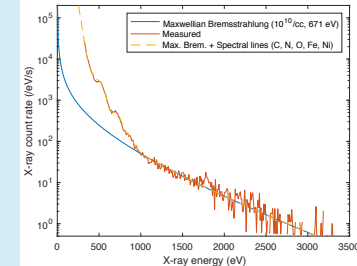

*Hot electrons demonstrated*



*Superconducting test coil*

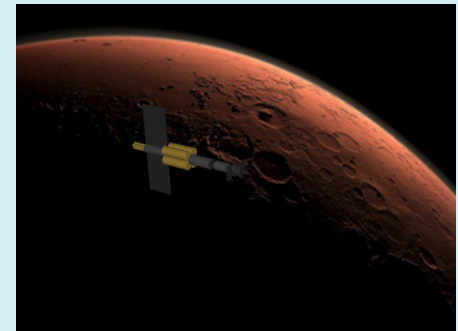

*Mars vehicle*

# Ongoing Work by Subsystem

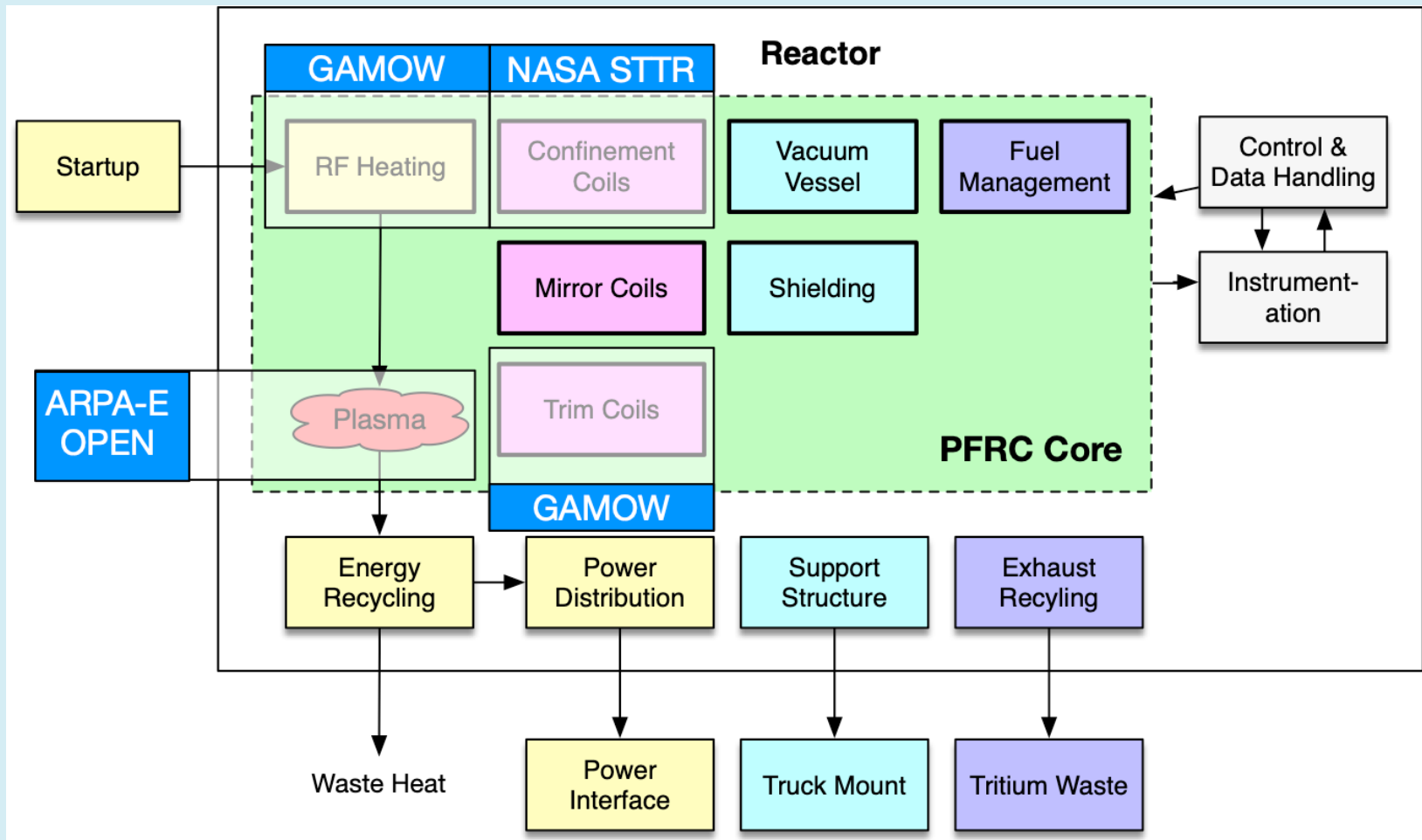

# Proposals in Progress

- U.S. Air Force AFWERX Energy Challenge/Open SBIR
  - Engineering design of complete mobile plant
    - Build on ARPA-E OPEN work
  - Research projects on Energy and Ash Removal Shell (EARS), shielding and heat engine
    - Nano-structures for neutron shielding
    - Heat exchanger and recuperator

# Proposed Development Plan

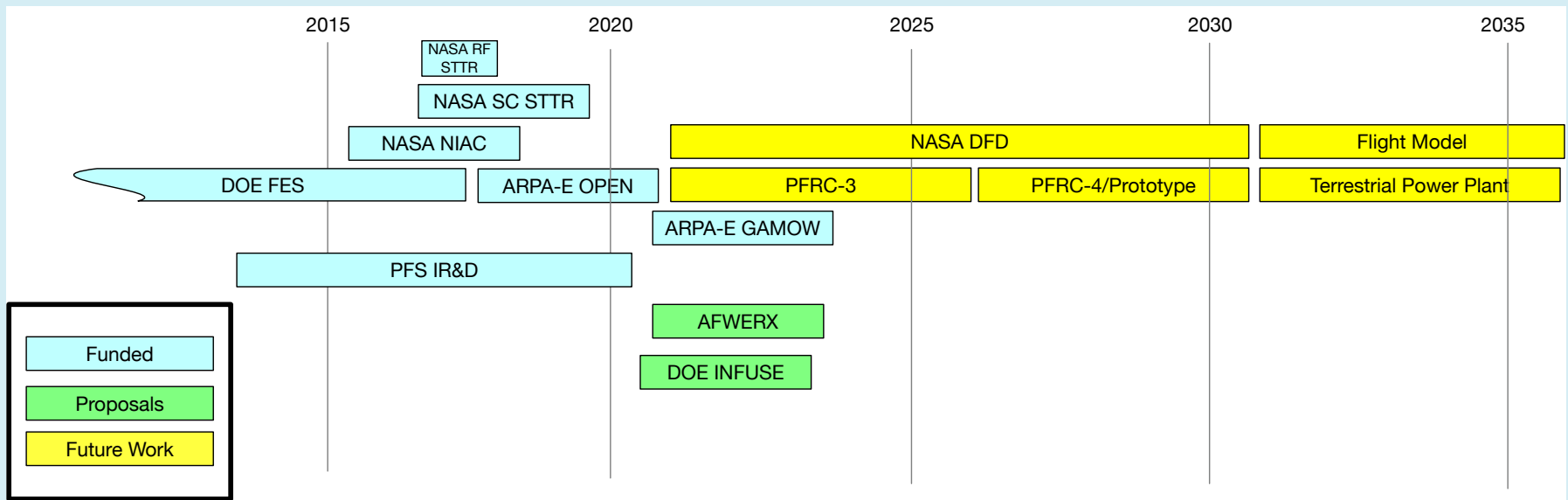

Total cost: \$111M with well-defined decision points

# Contact Information



Michael Paluszek  
[map@psatellite.com](mailto:map@psatellite.com)

Stephanie Thomas  
[sjthomas@psatellite.com](mailto:sjthomas@psatellite.com)

Dr. Charles Swanson  
[charles.swanson@psatellite.com](mailto:charles.swanson@psatellite.com)

Princeton Fusion Systems  
6 Market St. Suite 926  
Plainsboro, NJ 08536  
(609) 275-9606  
<http://www.psatellite.com>